



SF 300SE/A



Technical data

Current: 200-230 V, 50-60 Hz

Max vacuum:..... >2100 mm Vp

Air flow: 160/280 m³/h

Filter: 3-layer filter (Pre-, Fine- and Micro-filter), with an efficiency of 99,997% for particles >0,0003 mm. A carbon filter is available on request.

Handling

Attach one end of the hose to the inlet pipe of the smoke filter and the other end to the nozzle. Connect pliers sensor to ground cable on the welding machine. When welding is started, the smoke filter will start running automatically. After finishing welding, the smoke filter will continue to run for about 15-30 sec's. Switch for manual start and stop.

Maintenance

The SF 300SE/A has a spark trap in the filter gable, behind the inlet pipe. This trap is easily accessible by releasing the toggle fasteners and unhooking the gable. The spark trap must be checked and cleaned regularly.

Changing the filter

When the filter is full, the filter changing LED on top of the unit will light up. Please note that the SF 300SE/A is equipped with an automatic switch that will cut the current supply to the engines unless the filter is changed shortly after the LED has lit up.



ALWAYS change the filter if it is full. Cleaning the filter will damage it and may cause engine breakdown.

Service

After 1000-1200 working hours, the engine carbon-brushes must be changed. Your retailer will do that for you.

Trouble shooting

When the filter is full, shortly after the LED has lit up, the engines will switch off. After changing filters, the smoke filter should start running again. If the filter LED does not light up before the engines switches off, either the carbon-brushes are used up or the filter LED broken.

Please contact your nearest retailer for service.

Exploded view

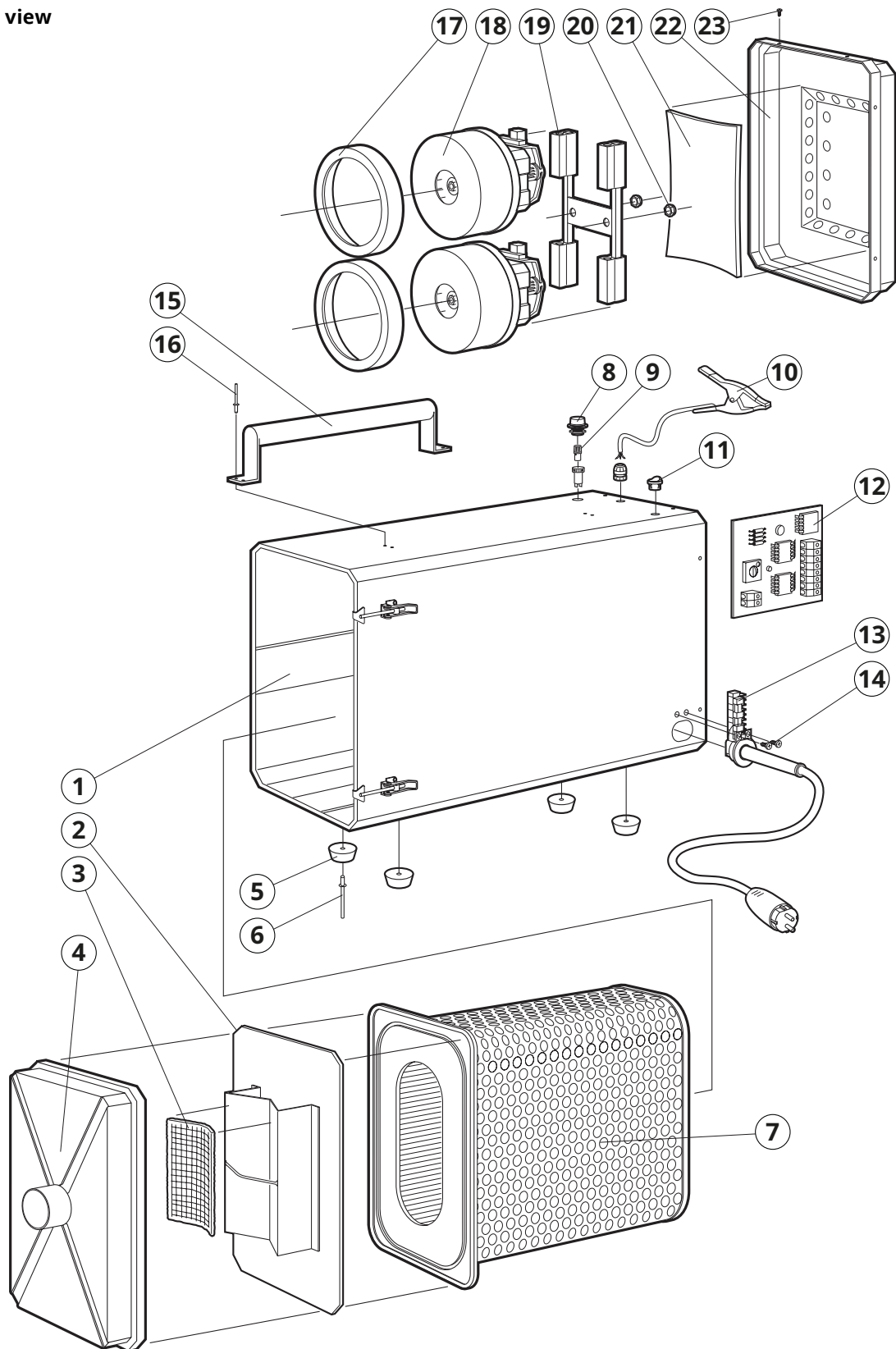

EXTRACTION ARMS • VEHICLE EXHAUST EXTRACTION • FANS • FILTERS • CURTAINS • CONTROLS

FUMEX